

Part Reference	Description
	Tropical Cyclone (Surface Fix)

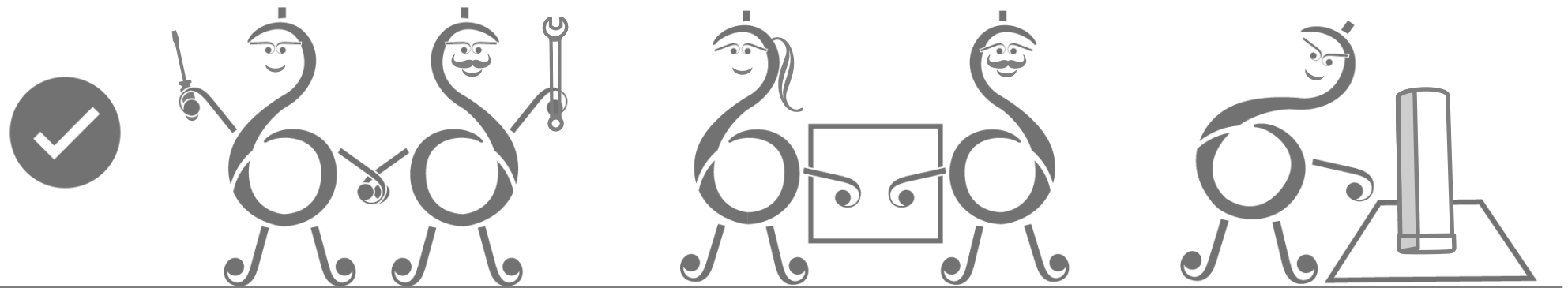

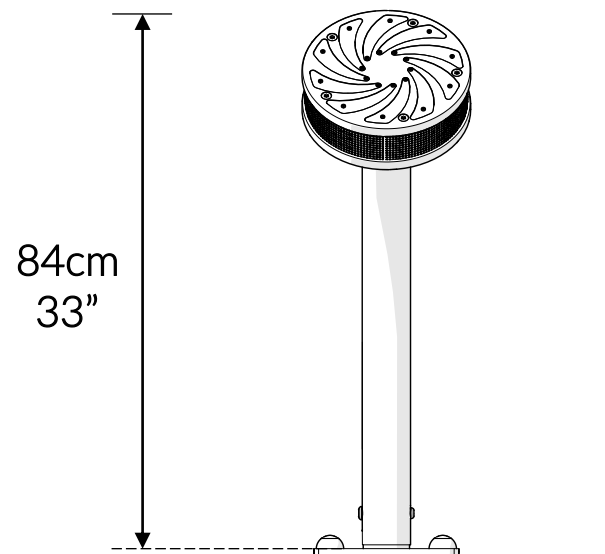

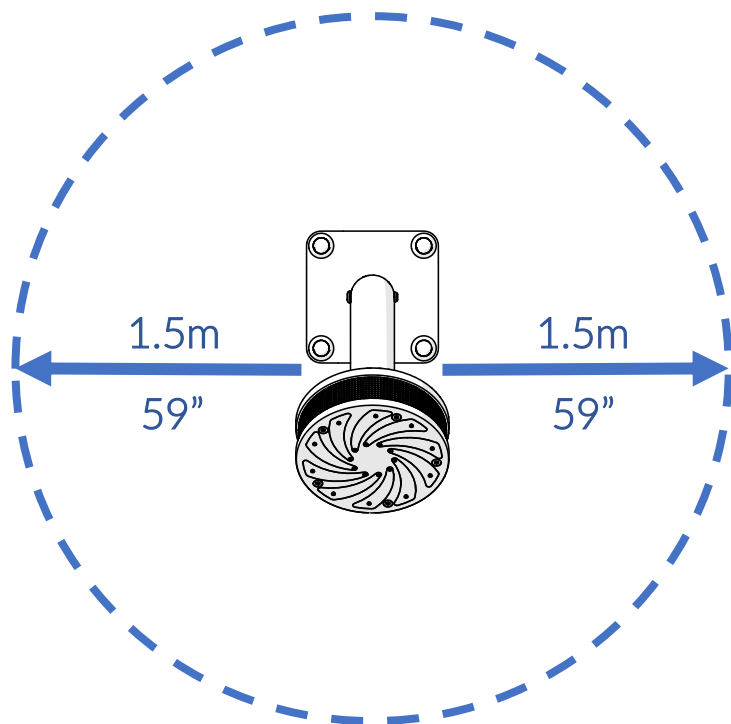

Check Risk Assessment

Packages

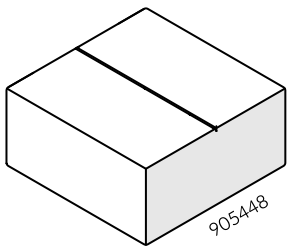

x1

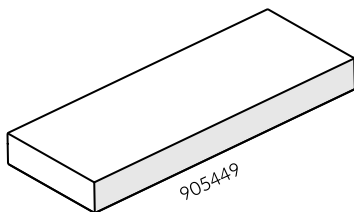

x1

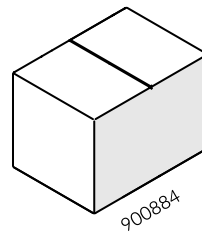

x1

		L	W	H	Weight	Net
x1	905448	27cm / 11"	27cm / 11"	13cm / 5"	3.5kg / 8lbs	
x1	905449	80cm / 31"	30cm / 12"	8.5cm / 3"	3.5kg / 8lbs	
x1	900884	32cm / 12.5"	23cm / 9"	23cm / 9"	6kg / 13lbs	

Tools required (not supplied)

¼" Bit Driver Ratchet

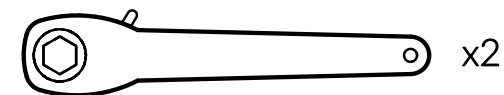

Tape Measure

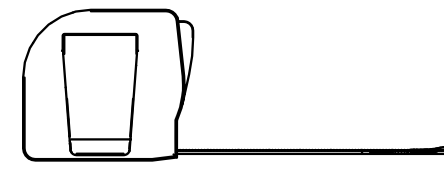

905448

① x1
805447

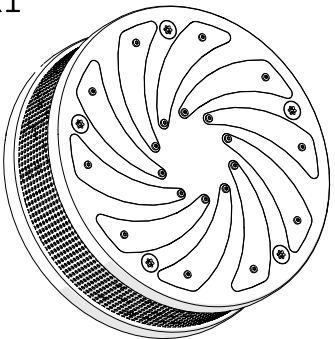

17mm x1
605443



905449

② x1
805201

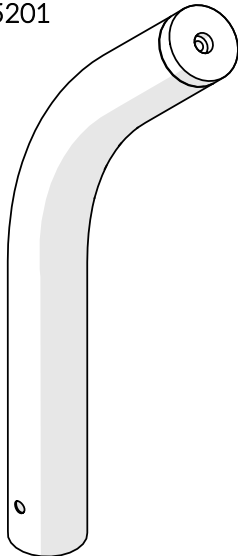

900884

③ x1
800878

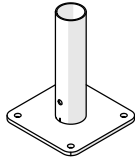

Ⓐ x1
500667



Ⓑ x1
500613



Ⓒ x4
601543



Ⓓ x4
601542



TX45 x2
500720



Not to scale

1.

1.1

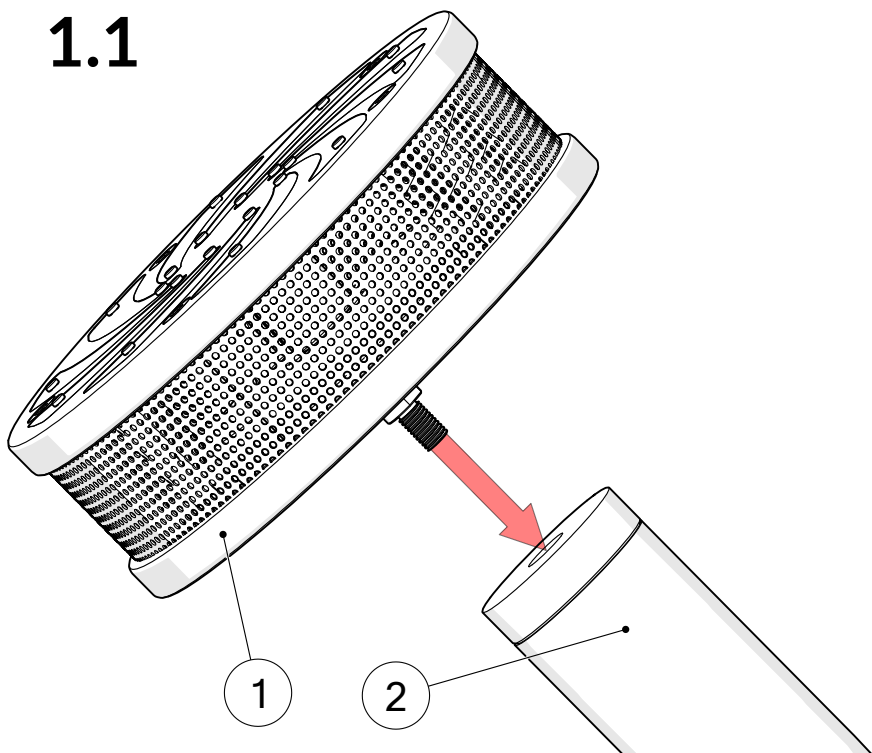

1.2

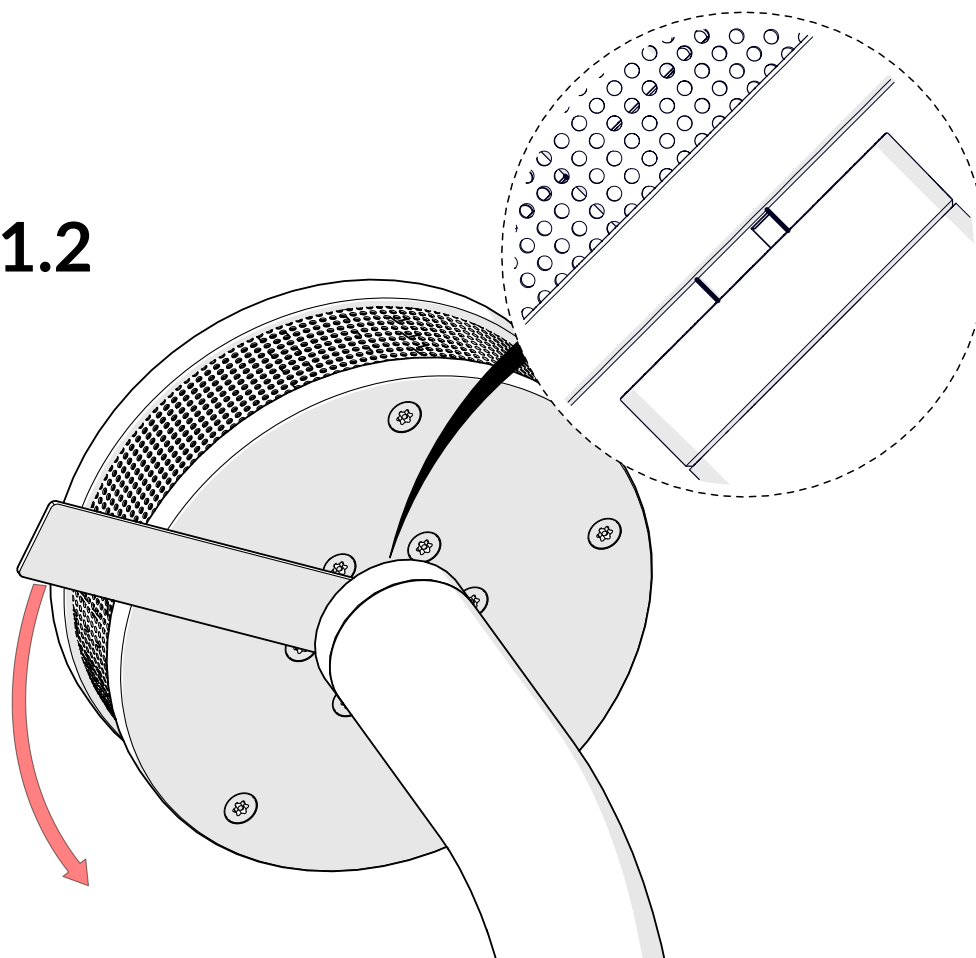

17mm

2.

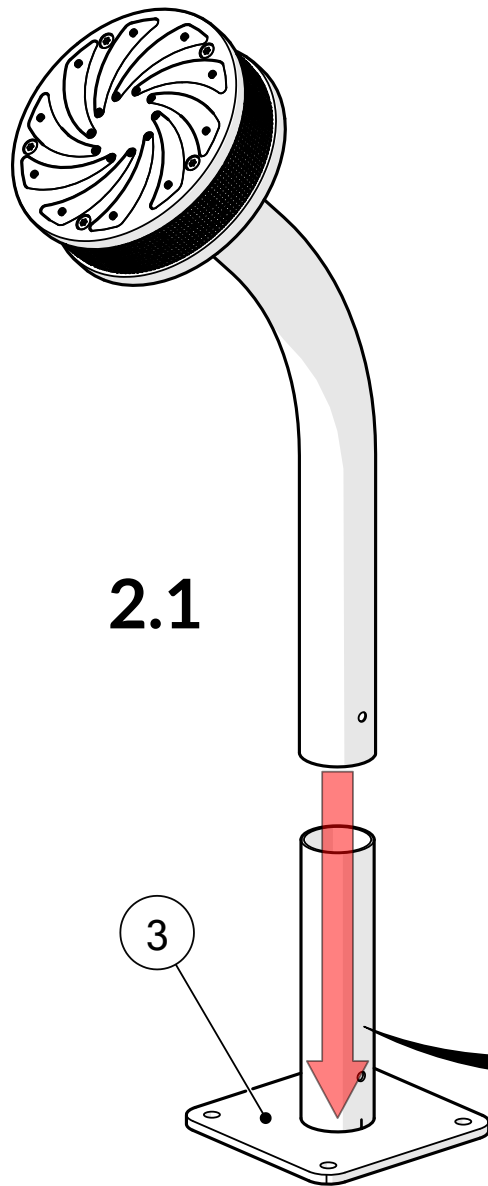

2.1

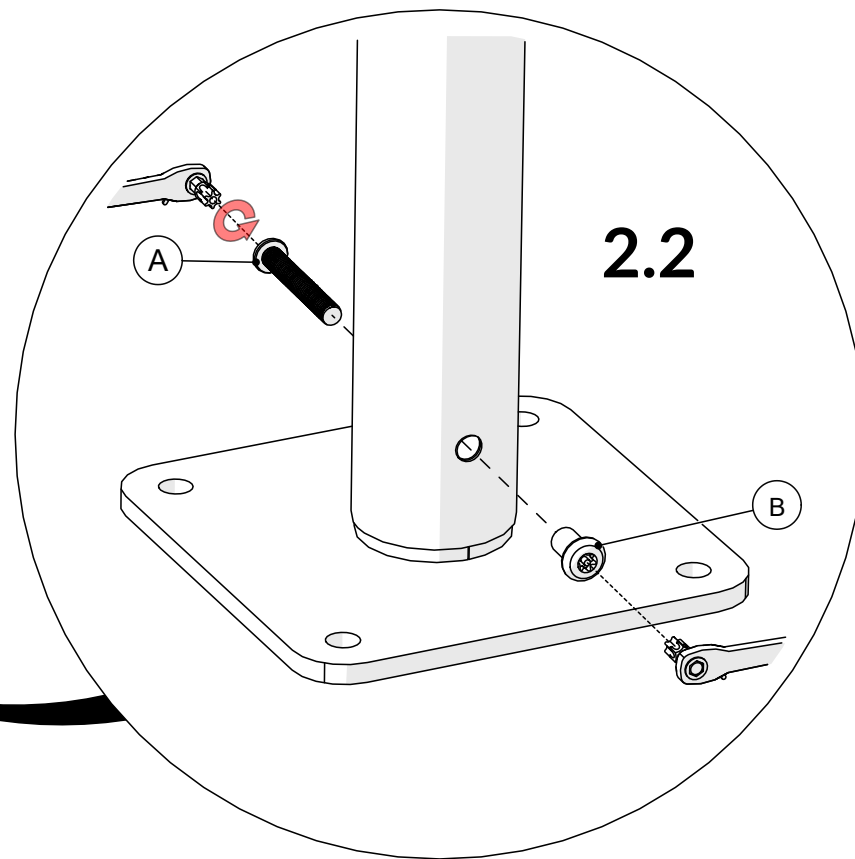

2.2

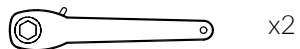

x2

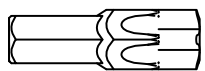

x2 TX45

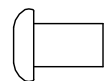
A		x1
B		x1

3.

Surface fixing should not present a hazard



Refer to your local Health & Safety standards

C		x4
D		x4

Surface

Example fixing

	Wood		x4
	Concrete		x4
	Brick		x4

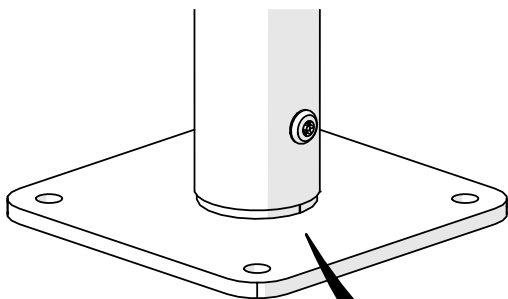

x4

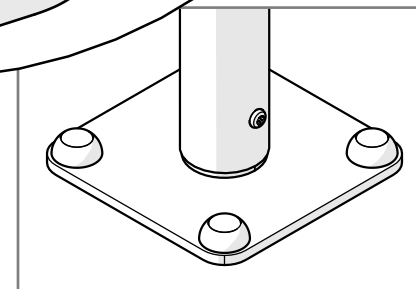
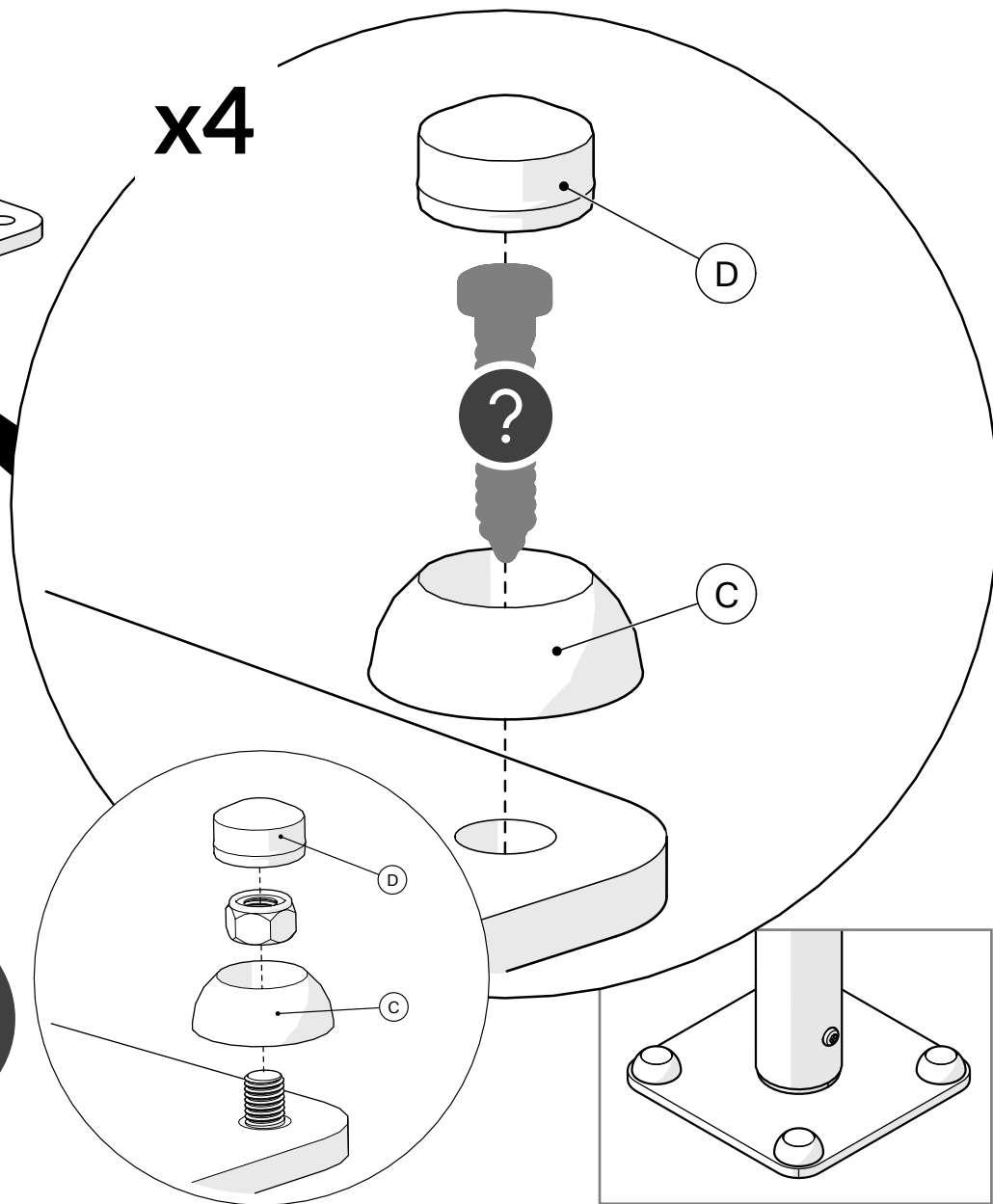

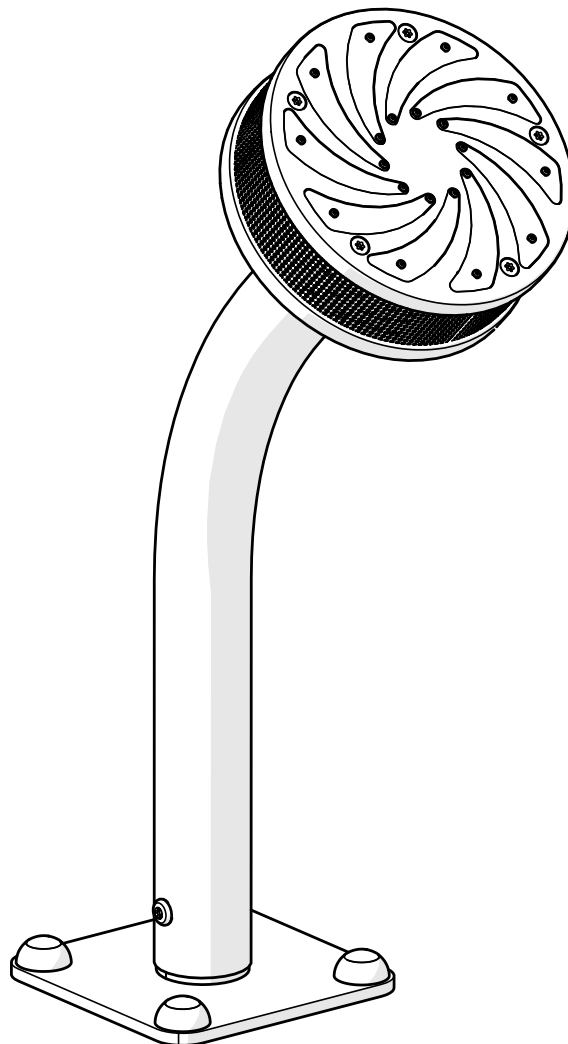

percussionplay.com



info@percussionplay.com



UK
[01730 235 180](tel:01730235180)

USA & CAN
[+1 \(866\) 882 9170](tel:+18668829170)

EUR & ROW
[+44 1730 235 180](tel:+441730235180)